

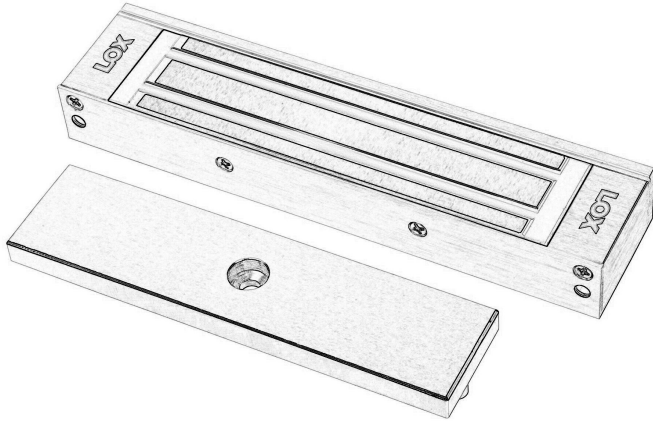

CCW30S/CCW30F Electromagnetic Lock

Wiring Instructions



CCW30S

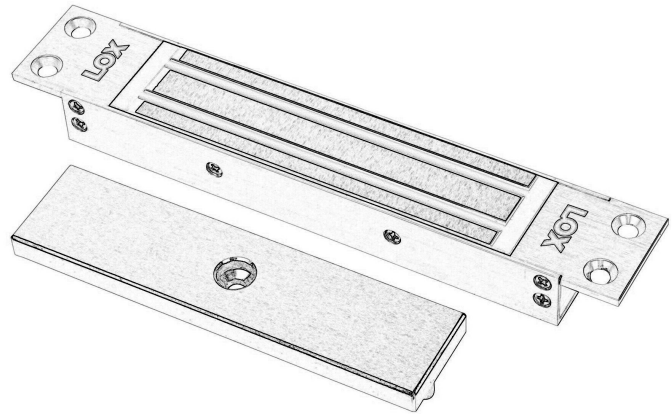

CCW30F

Wiring Instruction

For Wiring Installation Refer to Figure 1.

The **CCW30S** and **CCW30F** Electromagnetic Locks requires a filtered and regulated DC Power Source for optimal performance. Both CCW30 model are single Magnetic Lock with 12 or 24 volt settings. The casing adjacent to the cable entry needs to be removed to access the voltage selection shunts.

THE DEFAULT VOLTAGE SETTING IS 24 VOLTS D.C. - OPERATING THE LOCK AT 12 VOLT WITHOUT CHANGING THE VOLTAGE SHUNTS WILL DRAMATICALLY REDUCE THE HOLDING FORCE.

Check the position of the two shunts located on the PCB. A single shunt across pins 2 and 3 will set the operating voltage to 24 volts. A shunt between pins 1 and 2 and a shunt between pins 3 and 4 sets the operating voltage to 12 volts.

These voltage shunts must be adjusted before 12VDC or 24VDC is applied to the Electromagnetic lock to prevent damage to the unit. The voltage shunts are accessible by removing the end cap adjacent to the wiring entry.

The (+) lead of the Power Source is connected to **RED** lead of the PCB and the (-) lead is connected to **WHITE** lead of the PCB. The operating switch or controlling contacts must be installed between the power source and the Magnetic Lock to reduce operating time of the Magnetic Lock to a minimum.

Voltage/current: 12VDC 0.370A, 24VDC 0.185A - Default operating voltage factory set to 24 volts.

Installation Tips

Do not tighten the armature plate tight against the door. The armature plate must be remained movable to allow surface alignment with the magnet face. The Magnetic Lock will lose holding force without this floating alignment.

Do not trim the rubber washer mounted on the head of the armature bolt. Trimming this rubber will adversely effect the operation of Magnetic Lock.

Trouble Shooting

Problem	Possible Cause	Solution
Door will not lock	No DC voltage to lock.	Check power supply and wiring to magnetic lock.
Reduced holding force	Bad physical contact between armature plate and face of magnet.	Ensure mating surfaces are clean and in proper alignment and the armature plate floats freely. Check magnetic lock for low voltage or wrong voltage setting.
Delay in door release	Circuit switch is not between magnetic lock and power source. Secondary diode installed across magnetic lock.	Re-wire circuit switch between magnetic lock and power source. Remove this diode. Voltage spike protection is on the PCB.

Maintenance

Contacting surface of the Electromagnet and Armature Plate must be kept free of contaminating materials. Surfaces should be cleaned periodically with a non-abrasive cleaner. Do not spray the Electromagnet or Armature Plate surface with any chemicals such as lacquer, etc. This will cause serious problems with the release of the magnetic Lock and its Armature Plate resulting in serious safety problems.

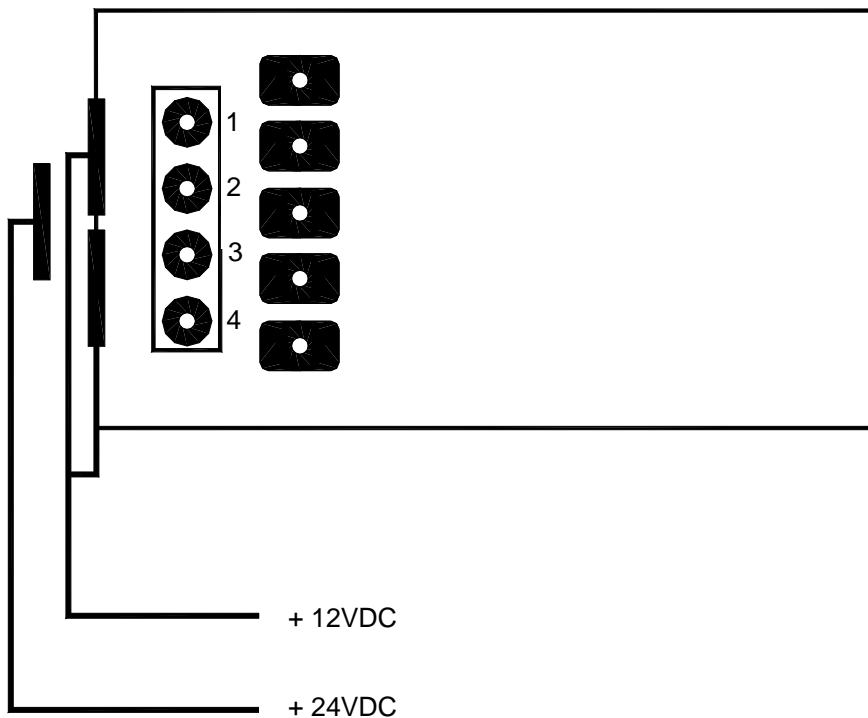

VOLTAGE SETTING

FIGURE 1